



FasNSeal®W2 DOUBLE WALL VENT SYSTEMS INSTALLATION INSTRUCTIONS

FasNSeal®W2, manufactured by ProTech Manufacturing, Inc. (PTM), is a special stainless steel vent system for gas fired appliances listed as Category II, III, and IV or in Canada, Type BH Gas Venting Systems as noted in ULC-636, with a rated operating temperature of 480 Degrees F (249 Degrees C), and a rated positive pressure of 6" Water Column. **FasNSeal®W2 must be installed by an experienced professional familiar with the operation and maintenance of heating appliances and venting. Before installing this product, examine all components for possible shipping damage and read the complete installation manual. Failure to follow proper installation procedures, including vent pitch and improper appliance connections may cause unsafe conditions.** ProTech Systems, Inc. recommends the system to be inspected once a year by a qualified service technician.

When venting Category II, III, or IV appliances, FasNSeal®W2 or FasNSeal® single wall must be used for the entire length of the system. Do not mix pipe, fittings, or joining methods from different manufacturers. **See the FasNSeal®W2 catalog number 1189 for a complete list of parts and products.** Every vent system must be planned and installed for optimum performance and safety. The venting system must be free to expand and contract and must be supported in accordance with these instructions. (Check for unrestricted vent movement through walls, ceilings, and roof penetrations). Refer to the gas appliance manufacturer's instructions to determine venting requirements and limitations with respect to installation and use of the appliance. **It is the responsibility of the installer to contact local building and fire officials concerning any installation restrictions and/or inspection requirements that may apply.** Permits may be required before starting an installation. This product must be installed in accordance with local building code requirements as well as National codes: USA - National Fuel Gas Code ANSI-Z223.1 or NFPA Standard 54, or NFPA 211. In CANADA - CAN/CGA-B149.1 or CAN/CGA-B149.2 Propane Installation Code as applicable.

GENERAL INSTALLATION REQUIREMENTS

Failure to conform to these installation instructions and all applicable codes may result in catastrophic property damage, personal injury, or death. These instructions are a guide to assist a professional installer.

- Proper operation of the vent system and appliance depends on the use and correct assembly of all parts specified by PTS for a particular installation.
- Tee sections should only be incorporated in conjunction with a drain on appliances tested for use with a drain, or if allowed by the appliance manufacturer for multiple appliance connections.
- If required by the appliance manufacturer, a drain fitting must be located as close as possible to the appliance flue outlet. Depending on the arrangement of the vent, **more than one drain may be required.** Unless a drain fitting is supplied with the appliance, install a FasNSeal®W2 Drain Fitting.
- More than one Category II, III or IV appliance may not be connected into the same vent system, unless the appliance manufacturer specifically approved such a system and the appliances are designed for multiple venting. Category III or IV appliances MAY NOT share any part of their vent system with a natural draft appliance.
- FasNSeal®W2 must not come in contact with plumbing or electrical systems.
- FasNSeal®W2 must maintain proper clearance to combustibles over its entire length.
- Except for installation in one or two family dwellings, a vent system that extends through any zone above that on which the connected appliance is located, shall be provided with an enclosure having a fire resistance rating equal to or greater than that of the floor or roof assemblies through which it passes.
- Never install FasNSeal®W2 on an appliance that is not listed for use with a Special Gas Vent or Type BH vent.
- FasNSeal®W2 shall not be routed into, through, or within any vent, such as an existing masonry or factory-built chimney, that is connected to another appliance.
- Do not install insulation in any required clearance space around FasNSeal®W2.

NOTE: FOLLOW APPLIANCE MANUFACTURER'S REDUCTIONS FOR ELBOWS.

VENT SIZE AND LENGTH

Refer to the appliance manufacturer's installation instructions for proper size and vent configuration. Follow any horizontal/vertical length and height limitations, minimum clearances (air space) to combustibles, or specifications for the use of Elbows, Tees, or Drain Tees.



FasNSeal®W2 ADJUSTABLE VENT LENGTH

The FasNSeal®W2 Adjustable Vent Length is available in all diameters and allows the installer to easily adjust the vertical or horizontal length of a vent system, eliminating piecing together several vent lengths.

The W2-WT Wall Thimble already incorporates the W2-AVL. In most system layouts, this provides enough adjustability for the horizontal vent run.

Use the W2-AVL vertically for easy adjustment of the required minimum 1/4" per foot pitch.

Technical details about the stand alone W2-AVL: The overall length of all W2 Adjustable Vent Length is 18" (1).

The female end (2) measures 2", leaving 12" to telescope into a standard vent length.

The W2-AVL must penetrate no less than 4" into a standard vent length (3) to assure a good seal and structural stability.

This leaves up to 12" in true axial adjustability (4).

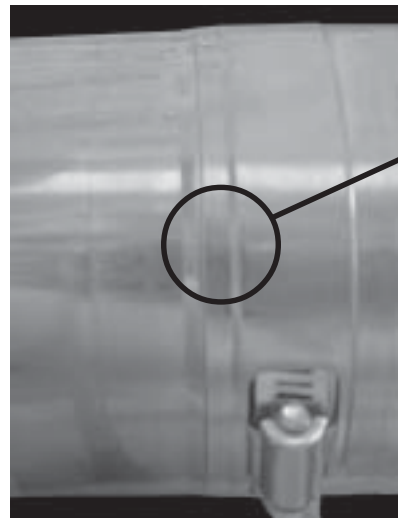
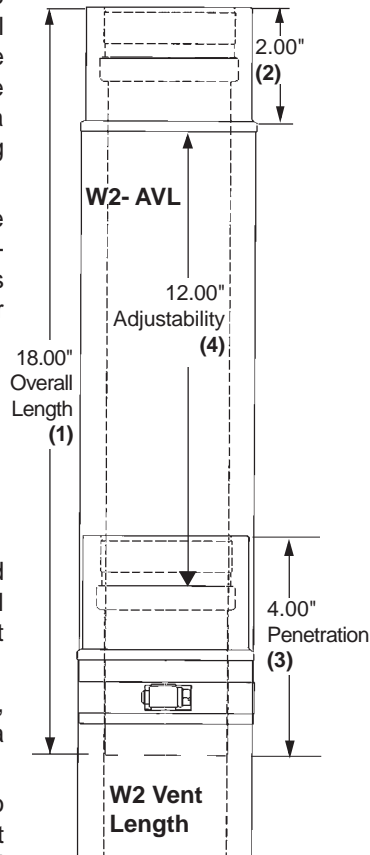

Stop bead on male end must be pushed directly against the flared end of the female end. When checking the inside of the joint, the gasket is fully covered and out of sight.

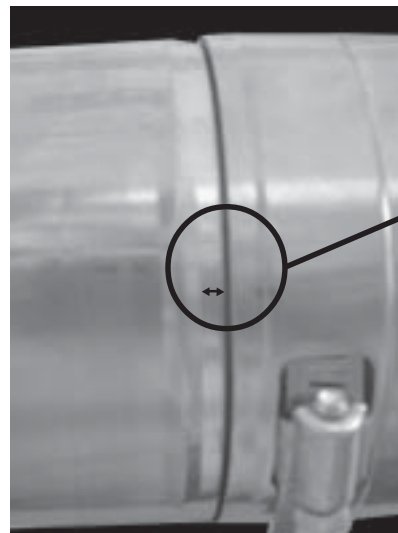

JOINT CONNECTIONS

The female end of each FasNSeal®W2 component incorporates a sealing gasket. The mechanical locking band is built into the outer tube of the FasNSeal®W2 male end. Examine all components prior to installation. Gaskets must be in proper position or flue gases could leak and result in carbon monoxide poisoning. Adjustable vent lengths are available in all diameters.

1. Insert the FasNSeal®W2 male end into the FasNSeal®W2 female end. Push the units together and turn them clockwise until the outer tube of the male end reaches the center of the raised bead on the female end (see photo). From within the tube, the sealing gasket must not be visible. This creates the needed airtight seal for Category II, III, or IV appliances. Align seams on outer tubes and orient them upward in all horizontal applications.
2. Tighten the locking band with a nut driver until snug and then rotate an additional 1/4 turn.

Before proceeding, recheck all joints and ensure all female outer sections extend to the center of raised bead on the male outer and all clamps are tightened.

APPLIANCE CONNECTION

Connect FasNSeal®W2 to the appliance flue collar as directed in the appliance manufacturer's instructions. If the appliance flue collar is not designed to accept FasNSeal®W2 directly, an adaptor may be available from the appliance manufacturer or PTS. Some appliance adapters may require a Single Wall to Double Wall Transition Adapter.

CONDENSATE DRAINS

If instructions or local regulations call for a condensate drain, use a FasNSeal®W2 Drain Fitting of appropriate size to connect the Tee into the sanitary sewer drain. Follow all local and national codes for draining acidic effluent. Always create a siphon loop in the plastic tube. Do not use copper as a drain as it may corrode.

HORIZONTAL, THROUGH THE WALL INSTALLATION

- When venting through a sidewall, terminate the system not less than 12" (.3m) above the ground and above the snow line in geographical areas where snow accumulates. The termination area must be kept clear of snow and ice at all times.
- Terminate the system at least 7' (2.1m) above a public walkway or driveway, no less than 6' (1.8m) from the combustion air intake of any appliance or 3' (.9m) from any other building opening, gas utility meter, service regulator or the like. It also shall terminate at least 3' (.9m) above any forced air inlet within 10' (3.1m) and shall terminate at least 4' (1.2m) below, 4' horizontally from or 1' (.3m) above any door, window, or gravity air inlet into any building as provided in the National Fuel Gas Code ANSI Z223.1 and NFPA 54. Proper judgment may require greater distances depending on the size of the equipment installed or to allow for snow drifting or falling from overhead roofs or trees. The termination should be away from trees, shrubs or decorative items as flue gases could cause damage.
- The total horizontal vent length from the appliance flue collar to the outside termination shall not be greater than specified in the appliance manufacturer's instructions. The vertical vent length into the Wall Thimble must be a minimum of 1" from combustible walls.

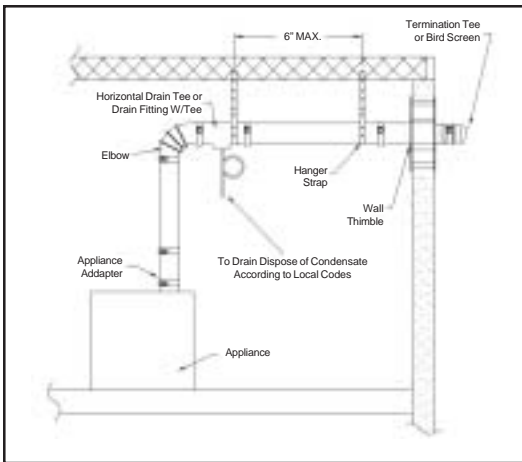

Side Wall Installation

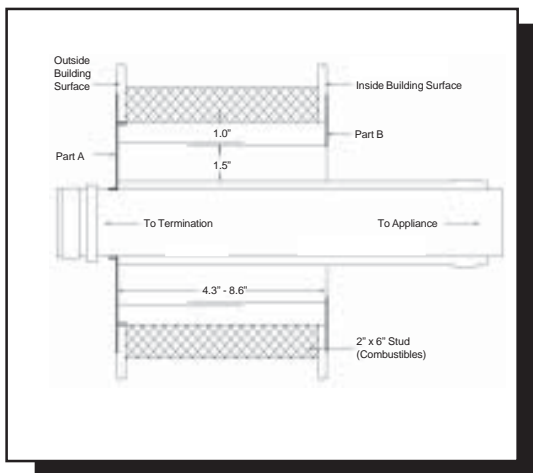

Wall Thimble Installation

- A horizontal installation shall have a slope (upwards or downwards for Category I, II, III, or IV appliances) of no less than 1/4" (6.4mm) every 12" (305mm) to prevent collection of condensates, formation of ice build up, or blockage at any location within the assembly. Refer to appliance manufacturer's installation instructions for further details regarding the installation of condensate drain fittings and the pitch of the system.
 - Use non-combustible hanger straps a minimum of every 6' (1.8m) to support the vent system from ceiling joints or other solid structures. Do not puncture the vent system!
1. Determine the location and install the Wall Thimble so that a continuous minimum slope of 1/4" per foot is maintained in the horizontal portion of the vent system.
- Condensate must flow and may not be retained in any part of the vent system.**
2. Cut the opening for the Wall Thimble to allow the spacer tabs protruding from the outer plate to sit comfortably within the opening. (See Wall Thimble Installation diagram)
 3. Position Part A into the opening so that the gasketed end of the Wall Thimble is located on the outside of the building.
 4. Apply a bead of silicone between the two surfaces and around the edges before nailing or screwing the plate on Part A to the outside building surface.
 5. From the inside, slide the sleeve of Part B onto the sleeve of Part A until Part B's plate is flush against the inside building surface. Fasten with screws or nails.
 6. NOTE: When terminating through a non-combustible wall, the wall thimble is optional.
 7. Use a Termination Tee, or Bird Screen to finish the system's exterior.
 8. Assemble FasNSeal®W2 from the appliance towards the Wall Thimble, beginning with the Appliance Adapter, Vent Length or Tee. Refer to "Joint Connections" in these installation instructions for proper procedure. (See page 2)

Do not drill or penetrate any part of the vent system.

VERTICAL VENTING

- Terminate the system 6' (1.8m) from the combustion air intake of any appliance.
- Terminate the system at least 3' (.9m) from any other building opening, gas utility meter, service regulator or the like.
- Terminate the system at least 2' (.61m) above the roofline and any wall or vertical structure closer than 8' (2.4m). Additional support is required for systems that extend more than 6' (1.8m) above the roofline.
- Enclose residential exterior vent systems below the roof line to limit condensation and protect against mechanical failure.

- Install a Wall Bracket after every transition from horizontal to a vertical run of over 10' (3.05m), a minimum of every 12' (3.66m) of vertical run, and after any offset in the vertical run. (See Detailed FasNSeal® Wall Bracket Installation)
- Unless FasNSeal®W2 is installed in a fire rated shaft, a fire stop and support is required when penetrating fire rated floors, walls or ceilings.
- The total equivalent vent length from appliance flue collar to the termination shall not be greater than specified in the appliance manufacturer's installation instructions.
- A FasNSeal®W2 Rain Cap or any other provision as required by the appliance manufacturer must be used to keep rain or debris out of the vent.

1. Locate the path for the vent system.
2. Cut and frame openings in floors, ceilings, and roof to accommodate Fire Stops with the required clearances to combustibles.

3. Cut the opening so that the minimum clearance between the outer sleeve & any combustibles is maintained.

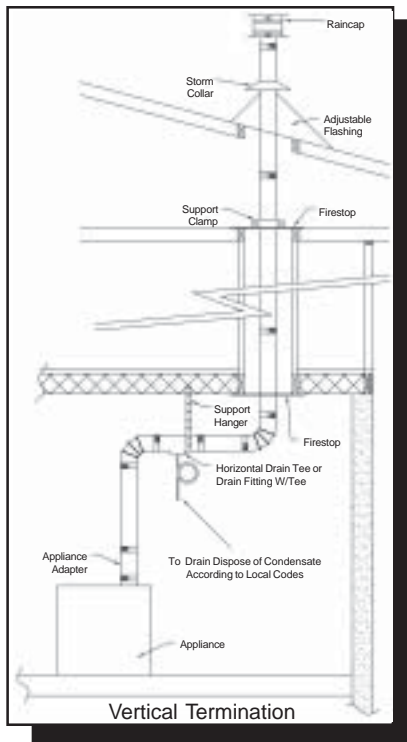

4. When installing on a pitched roof, place the Roof Flashing under the roofing material upslope from the vent and above the roofing material below the vent. Seal is required.
5. Begin installing FasNSeal®W2 from the appliance upward.
6. Once FasNSeal®W2 reaches the roofline, slide the pipe through the Roof Flashing.
7. Slide the Storm Collar over the pipe, applying a bead of silicone sealant where the Storm Collar contacts the pipe. The Storm Collar shall rest on the flashing. Tighten the clamp of the Storm Collar to achieve a snug fit.
8. Add additional vent lengths as needed.
9. Attach the Rain Cap to finish.
10. To inspect the vent system, open the locking band and remove the Rain Cap.

FasNSeal® EXTERIOR WALL BRACKETS

Pre-Installation

1. Wall Brackets must be securely fastened to a solid member of the building using appropriate fasteners; Tapcon screws for solid masonry, wood screws for wood framing or sheet metal screws for structural steel.
2. A Wall Bracket must be installed after any transition from horizontal to a vertical run of 10 feet or more, after every 12 feet of vertical run or after any offset in a vertical run.

Installation

1. Use the Wall Bracket as a template for making the hole locations on the wall surface.
2. If the Wall Bracket is secured to a masonry structure, drill 3/16 pilot holes for 1/4" Tapcon screws.
3. If the Wall Bracket is secured to a steel structure, drill and tap holes for 1/4-20 screws.
4. If the Wall Bracket is secured to a wood structure, it may be helpful to pre-drill for # 8 wood screws.
5. Always install a 1" diameter washer between each fastener and Wall Bracket.
6. Securely attach the Wall Bracket using the appropriate fasteners to the wall.
7. Tighten Wall Bracket to FasNSeal®W2 tubing using 45-50 in/lb torque.

VENTING THROUGH A MASONRY CHIMNEY

When using the FasNSeal®W2 Vent System inside a masonry structure, follow FasNSeal® Installation Guide for Lining a Masonry Chimney (Lit # 1225) for general guidelines. The detailed instructions can be obtained by calling PTS at **1.800.766.3473** or downloading them from our website www.protechinfo.com/lit_library.html **When using FasNSeal®W2 to vent Category I natural draft appliances, remove the gaskets.**

IMPORTANT NOTICE

The listing for this product is void if components other than those supplied as Listed Components by PTS are used. All warranties, stated or implied, are void if this product and the appliances to which it is connected are not installed in accordance with their respective instructions and local code requirements.

After the installation, check the entire system to make sure all joints are secure and sealed correctly. The seams and joints must be checked for gas tightness when using the venting system with Category II, III or IV appliances. ProTech Systems recommends that the entire system be checked by a qualified inspector at least once annually following initial installation.

The installation must conform to the requirements of the appliance manufacturer's instructions, the National Fuel Gas Code and local codes and regulations.

CLEARANCE TO COMBUSTIBLES					
Rated Operating Temperature, °F		Minimum Clearance Enclosed		Clearance Unenclosed	
		Horizontal	Vertical	Horizontal	Vertical
3" & 4"	300°F	3"	1"	1"	1"
	400°F	6"	1"	3"	1"
	480°F	6"	4"	3"	1"
5" - 16"	300°F	3"	1"	1"	1"
	400°F	6"	1"	3"	1"
	480°F	6"	6"	3"	3"

Rated Operating Temperature of 300°F = Max Flue Gas Temperature of 375°F
 Rated Operating Temperature of 480°F = Max Flue Gas Temperature of 550°F